



APPROACH

Autograph

All-Tech Bodyshell



The height of refinement

APPROACH *Autograph*

Alu-Tech Bodyshell

The new Bailey Approach Autograph - the height of refinement

Since its entry into the motorhome market three years ago Bailey of Bristol has quickly established a reputation for building vehicles which provide the unique combination of superior performance, award-winning design and unbeatable value for money. Our second range, the Approach Autograph, takes this successful formula a stage further by broadening the overall appeal of our motorhomes and thus making them an attractive proposition to a wider audience.

Alu-Tech

Model: Approach Autograph 745





What makes our motorhomes different?



STRUCTURAL INTERLOCKING ALUMINIUM EXTRUSION EXTERNAL FRAMEWORK

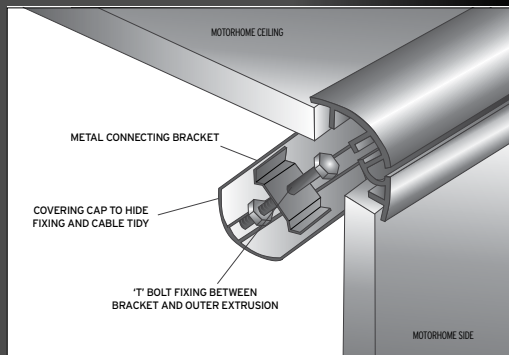

All Bailey motorhomes are coach-built using the high performance Alu-Tech construction system, seen by many leading observers as the most significant development in leisure vehicle production technology for over thirty years.

Providing genuine design innovation it is a construction system so unique that it has five new patents registered and one which has required the creation of over one hundred new bespoke component parts to build it. As a result Bailey leisure vehicles are now some of the best engineered and the most technically advanced products on the market and ones which offer real and tangible benefits of ownership to our customers. Most notably these include:

THERMAL PERFORMANCE

Thicker body shell panels featuring superior grade polystyrene, plus additional localised insulation in traditional cold spot areas have greatly enhanced the thermal properties of the vehicle. As a result all of our motorhomes built using the Alu-Tech construction system have achieved the Grade III Classification of Thermal Insulation for EN1646-1, keeping you warm in winter and cool in summer, as well as making your vehicle more economical to own.

STRUCTURAL INTEGRITY

Engineered to ensure it remains weatherproof and structurally sound, the Alu-Tech body shell sets new standards in durability. Starting with an interlocking aluminium framework that cuts the number of external joints and fixing points by 90%, every conceivable effort has been made to reduce the number of potential water access points and thus improve the overall integrity of the protective shell. While timber free body shell panels featuring a composite plastic internal skeleton offer a second line of defence, limiting the impact any possible ingress may cause. The bodyshell assembly, including the interface sections between cab and habitation area, consists solely of fully laminated panels cloaked in a GRP outer skin enhancing both the strength, durability and rigidity of the structure.

The resulting leisure vehicles have been subjected to a continuous series of accelerated life and structural crash tests as well as a climate control chamber examination at the renowned Millbrook Proving Ground to ensure that every aspect of the design has been thoroughly evaluated.

To date over 30,000 caravans and motorhomes have been built using this ground-breaking technology.

For more information on the Alu-Tech construction system and Bailey's on-going product development programme please visit www.baileyofbristol.co.uk

Alu-Tech



On the road...

Designed to be driven all models are powered by a 2.2 Hdi 130 bhp engine complete with a 6-speed manual gearbox housed in a Peugeot Boxer Euro 5 cab and thus benefit from the resulting improvements in performance and reduction in vehicle emissions. Driver and passenger comfort whilst en-route is also catered for with a pair of fully adjustable front swivel seats with twin arm rests and new map pocket, cab air conditioning and engine cruise control all included as standard.

The fully-specified cab is matched with a new ultra-low profile lightweight AL-KO AMC chassis which, with its lower centre of gravity, provides a more balanced weight distribution that improves road holding and braking efficiency as well as allowing for increases in user payloads and improving access in and out of the vehicle via a low level entrance step.

Safety considerations remain of paramount importance and thought has been given to this aspect of the design throughout the vehicle, as highlighted by the fitment of dual air bags in the front cab of all models, Michelin premium tyres and a spare wheel housed in an automotive style floor mounted wind down carrier. In addition following the successful completion of the crash test research programme at the Millbrook Proving Ground additional strengthening has been made to the floor and furniture in the dedicated rear passenger areas to enhance the effectiveness of the fitted three point seat belts (model specific).



Fully adjustable front swivel seats with twin arm rests



Peugeot 2.2 Hdi 130 bhp engine

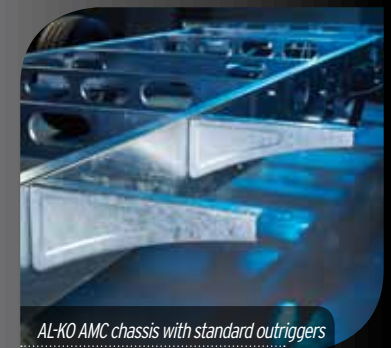

AL-KO AMC chassis with standard outriggers



On arrival...

As practical as they are comfortable these well thought-out motorhomes include a variety of new features designed to make your life easier. Models now come supplied with a high performance 110Ah auxiliary Banner leisure battery, housed in a convenient new under floor storage compartment, to give greater independence away from a mains power source. Whilst a 90/100 litre* fully insulated external fresh water tank and matching 90/100 litre* waste tank offer continuous supply for extended periods and in extreme weather conditions.

A host of new internal and external storage options facilitated by the new double skin floor construction have been incorporated into the designs to allow you to take advantage of the generous payload allowances available with every model. A new fully-specified Alde radiator heating system, complete with user-friendly digital control panel, has also been added to the equipment list to provide programmable heating en-route or on site - which combined with the superior thermal performance of the Alu-Tech bodyshell makes the Approach Autograph the ultimate four-season vehicle.

**Model specific.*



Banner leisure battery



Alde central heating system with digital control panel



Alde radiator heating system



Interior service access hatch

On holiday...

This eye-catching new range is available in a choice of six contrasting layouts including three established best-sellers (625, 740 and 745) plus three exciting new additions. Now included in the Autograph range, the three berth 540 is 5.99m long and 2.35m wide making it the smallest model within the range which is ideally suited for people with active lifestyles. This practical layout has a full width end washroom, central kitchen and an L-shape front lounge with drop down bed located above. The four berth 730 features a large front lounge, central kitchen and washroom plus an end bedroom with a transverse island bed. In contrast the one-of-a-kind 765 is a genuine low profile six berth family motorhome which includes a spacious rear lounge, central kitchen and washroom plus a totally unique longitudinal drop down bed located over a double front dinette.

Interior decor, featuring the trademark Bailey Walnut finish, has been expertly refined with new cabinetry featuring elegant curved profiles, dual-finish locker doors, high gloss worktops and polished chrome fittings to enhance the feeling of quality. While new design elements such as the ergonomic kitchen units with contrasting overhead locker system plus the additional new ambient and task lighting give the Approach Autograph range the all important wow factor.

Each model comes with a choice of either Trafalgar or Piccadilly luxurious soft furnishing options, featuring superior construction and premium quality fabrics, both of which are supplied with co-ordinating curtains and a pair of reversible scatter cushions.



Standard Trafalgar soft furnishings



Optional Picadilly soft furnishings



Approach Autograph 765 longitudinal drop down bed (bed linen available as a cost option)



Model: Approach Autograph 740 in standard Trafalgar upholstery



Model: Approach Autograph 745 in optional Picadilly upholstery (bed linen available as a cost option)

On holiday...

As people have come to expect from Bailey, models are extremely well specified and are packed with all the home comforts owners will need for relaxing and enjoyable holidays. Notably they include fully equipped kitchens, featuring the new Thetford Caprice combination anti-rattle oven with a dual-fuel hob including an electric hotplate, and cleverly designed washrooms all of which contain a separate fully lined cubicle containing an energy-saving EcoCamel shower.



Approach Autograph 765 washroom



Approach Autograph 740 kitchen



VEHICLE CONSTRUCTION

Peugeot Boxer Cab

Peugeot Euro 5 Boxer Cab supplied with a 3 year / 100,000 mile warranty & 12 months Peugeot Assist Cover • Peugeot 2.2 Hdi (High Pressure Direct Injection) 130 BHP engine with six speed manual gear box • NEW graphite cab with colour coded bumpers • Michelin premium branded tyres with tyre pressure sensors • Remote central locking for cab and habitation door • Electric windows • Electric heated wing mirrors with direction indicators • Variable power steering • Anti-lock braking system (ABS) • Electronic Brake Force Distribution (EBFD) • Emergency Brake Assist (EBA) • NEW Front and rear brake pad monitoring system • Engine immobiliser • Cruise control • Cab air conditioning • Driver and front passenger airbags • Fully adjustable upholstered driver and passenger seats with twin armrests • Map pockets on back of cab seats • Remis concertina windscreen and side window blinds • Removable cab carpet • NEW DAB Radio with Bluetooth connectivity, USB connection point (located in storage locker beneath the radio) and 2 door speakers • 2 x 12v sockets • NEW Daytime running lights

AL-KO AMC Chassis

NEW ultra-low profile wide track AL-KO AMC Chassis • NEW wind down floor mounted spare wheel carrier and spare wheel • Chassis prepared for towbar fitment Alu-Tech Bodyshell Habitation Area • Supplied with a 6-year transferable body shell integrity guarantee and a 3-year transferable manufacturers components warranty* • 4-year transferable extension to bodyshell integrity guarantee available as a cost option (making 10 years in total)* • 3-year transferable extension to manufacturers component warranty available as a cost option (making 6 years in total)* • EN-1646-1 Grade III classification for heating and thermal insulation • European Whole Vehicle Type Approval

Construction

Structural interlocking aluminium extrusion external framework with no external fixing points for additional strength and rigidity • Five part fully bonded exterior panel assembly system featuring: • Upper body panels manufactured using superior bead application laminating technology for a stronger more consistent bond • Upper body panels built using a timber free construction, incorporating a composite plastic internal skeleton, a high density polystyrene insulation and a GRP inner wall lining • Upper body panels cloaked in a single sheet impact resistant GRP outer skin for extra durability • Strengthened floor panel with GRP underside protection • NEW aerodynamic & aesthetically enhanced front and rear bodyshell profiles • NEW 'Polar white' bodyshell colour and co-ordinating graphics scheme

EXTERIOR FEATURES

NEW Dometic slim line flush fit habitation door with window, blind and bin plus a gas-strut assisted mechanism for smooth operation • NEW Dometic pleated full length door flyscreen • NEW low level insulated habitation door well step with non-slip mat, grab handle, curtain heater & courtesy light • NEW Polyplastic double glazed opening skylight with Remis night blind in front dome • Mini Heki roof light located over front lounge (model specific) & central kitchen • Midi Heki roof light located over rear lounge or bedroom • Polyplastic double glazed windows throughout with night latch ventilation • NEW Remis pleated flyscreens and blinds to all principal windows • NEW Remis splash proof blinds for kitchen & washroom windows • Centrally mounted easy access exterior gas locker compartment with capacity to store 2 x 10kg bottles • Propane/Butane en-route gas 30mb regulator mounted in gas locker compartment • NEW enlarged underbed storage area with larger exterior access doors (540,730,740,745) • NEW dedicated under floor storage area suitable for folding chairs and BBQs with exterior access (625,765) • NEW exterior 230v power inlet • NEW Vision Plus satellite connection provision • Fixing points for rear mounted cycle rack • Fixing points for exterior ladder and roof rack

INTERIOR FEATURES

NEW internal headroom of up to 2.10m (6'10") • Internal body width of 2.27m (7'5")

Furniture & Soft Furnishings

Bailey 'Walnut' furniture finish • NEW contrasting finish on kitchen cabinetry & overhead locker doors • NEW dual finish Italian design overhead locker doors • NEW high gloss kitchen & washroom worktop finish • NEW premium quality fixtures and fittings in polished chrome finish • NEW design slide out bed boxes for easy bed make up (730,740,745) • Roller slats for easy bed make up (625,765) • NEW drop down flaps on front bed box fascias for enhanced accessibility (730,740,745) • NEW deep-fill bed boxes with enhanced storage capacity (625,765) • NEW sprung beech bed box tops for additional comfort • NEW automatically operated ceiling mounted drop down double bed with sprung base (540,765) • NEW design fixed double beds with aluminium frames & gas strut assisted opening mechanism (730,740,745) • Free

standing and/or wall mounted table (both in 765) • Aircraft style overhead locker system with split level storage, domestic style metal hinges and positive door catches • Structural locker dividers with greater load bearing capacity • NEW standard 'Trafalgar' soft furnishings with co-ordinating curtains and two reversible scatter cushions • NEW optional 'Piccadilly' soft furnishings with co-ordinating curtains and two reversible scatter cushions • Fully sprung upholstery featuring premium quality fabrics, high density filling and superior cushion construction • De-Luxe sprung double bed mattresses (730,740,745) • NEW Foam filled double bed mattress on a sprung base (540,765) • Wood effect floor vinyl • NEW under floor dedicated storage area suitable for footwear (625,730,765) • Split section loose fit drop in carpets (50 oz pile density)

SERVICES

Electrical System

NEW premium 110 ampere/hour Banner leisure battery • NEW dedicated under floor twin leisure battery storage locker (one leisure battery supplied as standard specification) • Digital electrical control panel with touch screen operation • NEW 12v ambient and task lighting fittings throughout • NEW additional ambient over locker and under kitchen worktop lighting • NEW additional low level night lights • 230v power supply with up to five interior sockets • Up to two TV stations with 230v/12v/aerial sockets • Domestic style consumer unit with dedicated access door • Switch mode battery charger with 20 amps output • RCD/MCD protection for mains electric system • 25 metre mains connecting lead • Branded dual cone stereo speakers for superior sound quality • Pre-Wired for satellite and aerial connection and rear view camera.

Water & Heating Systems

NEW Alde Hydronic Compact3020 programmable radiator heating system with combined water heating • NEW touch screen user-friendly control panel • NEW washroom radiator • Dual fuel 3.4 Kw gas and 3 Kw electric power sources • Programmable daily timer • Floor mounted Whale Aqua smart II on-board water pump with Aquasourcelayflat filling pipe • Pressurised hot and cold fresh water system with self priming pump • Rigid pipe waste plumbing system • 90/100 litre external insulated fresh water tank with baffles and level sensor (540/625,730,740,745,765) • Fresh water tank heater for winter protection and overflow • 90/100 litre external waste water tank with baffles and level sensor (540/625,730,740,745,765) • Thetford C-260 cassette toilet with integrated header tank • Inboard shower unit with ceramic ball mixer tap and Ecocamel shower head • Fully lined separate shower cubicle with bi-fold partition door (540,625,740,745,765) • NEW Shower Curtain (730) • Washroom hand basin with ceramic ball mixer tap

KITCHEN EQUIPMENT

Dometic 103 litre refrigerator with electronic ignition and detachable full width freezer compartment. Capacity increases to 110 litres when freezer compartment is removed (540,625,730,765) • Dometic 117 litre refrigerator with electronic ignition and detachable full width freezer compartment. Capacity increases to 145 litres when freezer compartment is removed (740,745) • NEW Thetford Caprice anti-rattle combined oven, grill and hob with electronic ignition and flame failure device (625,730,740,745,765) • NEW Thetford Duplex anti-rattle combination oven and grill (540) • NEW dual-fuel hob with electric hotplate and 3 gas burners (625,730,740,745,765) • NEW Thetford 3-burner gas hob incorporating flush fitting glass hinged lid and conveniently located controls (540) • Stainless steel 800 watt microwave oven conveniently located at eye level in a dedicated overhead locker for enhanced sound proofing • NEW stainless steel circular kitchen sink with swan-neck mixer tap, circular washing up bowl, drainer and chopping board

SAFETY & SECURITY EQUIPMENT

AL-KO outriggers fitted to AMC Chassis for enhanced floor strength • 3-point seat belts on all designated travelling seats (540,745,765) • NEW design designated travel seat head rests (540,765) • Steel frame seat base supports for all designated travelling seats (540,745,765) • Steel framed seat base tops with Velcro base cushion fastenings for all designated travelling seats (540,745,765) • Steel framed structural bulkhead to support all rear-facing designated travelling seats (765) • Dedicated storage location for both free-standing & wall mounted tables • NEW high security door lock • Smoke alarm • Carbon monoxide alarm

**Terms and conditions apply. Please visit the Vehicle Warranty Section on www.baileyofbristol.co.uk for more information*



APPROACH
Autograph 540

APPROACH
Autograph 625

APPROACH
Autograph 730

APPROACH
Autograph 740

APPROACH
Autograph 745

APPROACH
Autograph 765

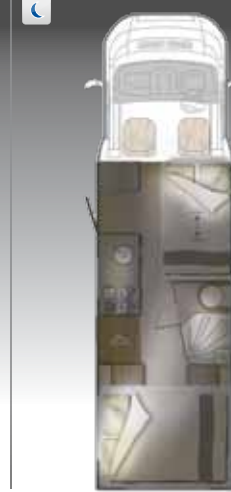
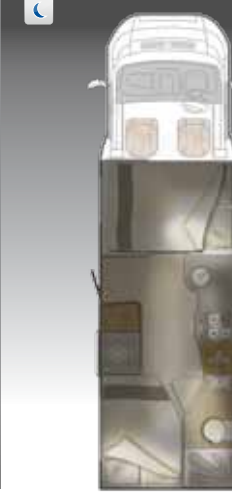
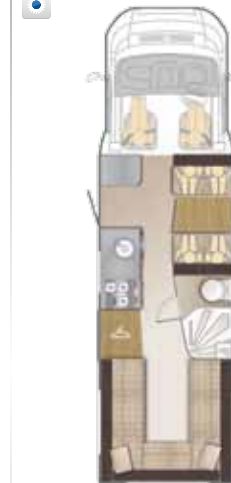



Technical specification

	540	625	730	740	745	765
Peugeot Engine	130bhp	130bhp	130bhp	130bhp	130bhp	130bhp
Engine Capacity	2198cc	2198cc	2198cc	2198cc	2198cc	2198cc
Engine Power	130bhp @ 3500rpm	130bhp @ 3500rpm	130bhp @ 3500rpm	130bhp @ 3500rpm	130bhp @ 3500rpm	130bhp @ 3500rpm
Engine Torque	320Nm @ 2000rpm	320Nm @ 2000rpm	320Nm @ 2000rpm	320Nm @ 2000rpm	320Nm @ 2000rpm	320Nm @ 2000rpm
Roof Profile	Low Profile	Low Profile	Low Profile	Low Profile	Low Profile	Low Profile
Chassis	AL-KO AMC	AL-KO AMC	AL-KO AMC	AL-KO AMC	AL-KO AMC	AL-KO AMC
Thermal Insulation Grade	3	3	3	3	3	3
Designated Travelling Seats	4	2	2	2	4	6
Berths	3	2	4	4	4	6
Overall Length	5.999m / 19'8"	6.640m / 21'9"	7.618m / 25'0"	7.450m / 24'5"	7.450m / 24'5"	7.450m / 24'5"
Overall Body Width (Inc marker lights & exc mirrors)	2.346m / 7'8"	2.412m / 7'11"	2.412m / 7'11"	2.412m / 7'11"	2.412m / 7'11"	2.412m / 7'11"
Overall Height	2.785m / 9'2"	2.785m / 9'2"	2.785m / 9'2"	2.785m / 9'2"	2.785m / 9'2"	2.785m / 9'2"
Tyre Size	215/70 R15 L1109Q	215/70 R15 L1109Q	215/70 R15 L1109Q	215/70 R15 L1109Q	215/70 R15 L1109Q	215/70 R15 L1109Q
MTPLM	3500kg / 68.9cwt	3500kg / 68.9cwt	3850kg / 75.8cwt	3500kg / 68.9cwt	3500kg / 68.9cwt	3850kg / 75.8cwt
MRO	2828kg / 55.7cwt	2995kg / 59.0cwt	3067kg / 60.4cwt	3042kg / 59.9cwt	3129kg / 61.6cwt	3217kg / 63.3cwt
Total User Payload	672kg / 13.2cwt	505kg / 9.9cwt	783kg / 15.4cwt	458kg / 9.0cwt	371kg / 7.3cwt	633kg / 12.5cwt
Maximum Recommended Trailer Weight	2000kg	2000kg	1650kg	2000kg	2000kg	1650kg
Gross Train Weight	5500kg	5500kg	5500kg	5500kg	5500kg	5500kg
Fresh Water Tank	90 litre	100 litre	100 litre	100 litre	100 litre	100 litre
Waste Water Tank	90 litre	100 litre	100 litre	100 litre	100 litre	100 litre
Gas Locker Capacity	2 x 10kg	2 x 10kg	2 x 10 Kg	2 x 10kg	2 x 10kg	2 x 10kg
Bed Sizes						
Front Double	-	-	1.224m x 2.250m (4'0" x 7'4")	1.224m x 2.250m (4'0" x 7'4")	1.210m x 2.240m (3'11" x 7'4")	1.030m x 1.840m (3'4" x 6'0")
Front N/S Single	-	-	-	-	-	-
Front O/S Single	-	-	-	-	-	-
Front Transverse single	2.250m x 0.630m (7'4" x 2'1")	-	-	-	-	-
Rear Double	-	2.210m x 1.800m (7'3" x 5'10")	1.792m x 1.332m (5'10" x 4'4")	1.980m x 1.350m (6'5" x 4'5")	1.980m x 1.350m (6'5" x 4'5")	2.200m x 1.790m (7'2" x 5'10")
Rear N/S Single	-	1.800m x 0.710m (5'10" x 2'4")	-	-	-	1.800m x 0.710m (5'10" x 2'4")
Rear O/S Single	-	1.800m x 0.710m (5'10" x 2'4")	-	-	-	1.800m x 0.710m (5'10" x 2'4")
Drop down Double	1.950m x 1.540m (6'4" x 5'0")*	-	-	-	-	1.230m x 1.835m (4'0" x 6'0")*

*Drop down double beds have a maximum load capacity of 200kg



 www.baileyofbristol.co.uk

 South Liberty Lane, Bristol BS3 2SS, England

 +44 (0)117 966 5967

This brochure does not constitute an offer by Bailey Caravans Ltd (Bailey). Bailey reserves the right to alter specifications and prices as market and supply conditions demand. Your Bailey retailer will confirm all specification details prior to you making your purchasing decision. E. & O. E. Bailey retailers sell our products of their own choice and not as agents of Bailey. Accordingly they have no authority to bind Bailey or to make any representation or undertaking whatsoever on behalf of Bailey. All household items illustrated in this brochure are used to enhance photography and are for display purposes only. They are not supplied with your motorhome. Photographic colour reproduction is subject to the limitations of the production process.

Design & Print: Kingsdown Photography: Alan Bond Issued: August 2014

