

50 years
of Smiles
Est. 1964



Powered by the greener
and more fuel efficient
Euro 5+ Engine

WWW.SWIFTGROUP.CO.UK



FIND OUT MORE SWIFTGROUP.CO.UK



This brochure does not constitute an offer by Swift Group Limited (Swift). Swift reserves the right to alter specifications and prices at any time as materials and conditions demand. Distributors and dealers sell Swift products on their own account and not as agents of Swift. Accordingly, they have no authority to bind Swift or to make any representation or undertaking whatsoever on behalf of Swift. All props are for photographic purposes only and are not included in the specification. Issued September 2014.

PART OF THE SWIFT GROUP
Cottingham · East Yorkshire · United Kingdom

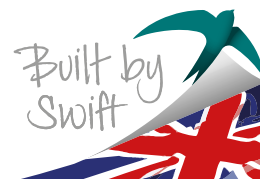

ESCAPE MOTORHOMES
2015 MODEL RANGE





TECHNICAL INNOVATION

A SMART MOVE WITH MODERN CONSTRUCTION

As the UK's leading leisure vehicle manufacturer, the Swift Group undertakes what is probably the most extensive research and testing program in the industry and we are constantly looking at new and better ways to construct our products. SMART is our intelligent construction system and it is now being introduced across our entire range of coachbuilt motorhomes.

SMART is based on proven technology and provides a Strong timber-less body with Modern desirable looks and an Aerodynamic shape that is highly Resilient to moisture, all wrapped up in a motorhome that has undergone comprehensive Testing.



Carefully developed, the system was only introduced once we were satisfied that it was truly fit for purpose.

Computer numerically controlled (CNC) cutting is used in the manufacturing process to provide accuracy and consistency time after time, to produce a high quality engineered product designed to give you a lifetime of SMILES..

For more details see www.swifttv.co.uk or www.swiftgroup.co.uk



MODERN

The SMART construction system uses Modern materials and has also been developed to ensure the exterior profiles maintain the Modern desirable looks our motorhomes are renowned for.



STRONG

The Strong timberless body frame uses 'PURE', a tough, hard polyurethane based product, that is totally impervious to water and has been proven through use.



AERODYNAMIC

We continue to lead the way in Aerodynamics using Computational Fluid Dynamics to help shape the bodysell for better fuel consumption.



RESILIENT

All fixing are made into the 'PURE' material to a pre-defined depth. 'PURE' is totally impervious to water and has no veins. This means there is no passage for water from the outer skin to the inner wallboard, making the caravan highly Resilient to moisture.



TESTED

Extensive safety and durability Testing at the Millbrook track, cold chamber Testing down to minus 15°C and sled crash Testing puts prototypes through conditions most products will never have to experience in a life time; all part of the Swift Ethos to deliver the best products to you.





ESCAPE WITH A SMILE

If you're looking for a great value new motorhome, then look no further, the Escape range is one of the UK's best selling motorhomes for a reason.

With Fiat's new cab, Swift Group's SMART intelligent construction system and sleeker exterior styling, with white gloss corner cappings and side skirts, they look even smarter on the road. Specification has also been enhanced, so if you're looking for your first new motorhome or just amazing value there really is no better choice.





Escape models offer an unrivalled combination of style, specification and value.

For the new season they are even better equipped with Truma Combi 4/6 heating and LED lighting. The new cab comes with captain's style seats and a radio with bluetooth phone connection, handy storage area and USB charging port.

Available in a choice of two low-line and four high-line models, all powered by a 130bhp Euro 5+ turbo diesel with a 6-speed gearbox and an automatic option, the Escape is ideal for young or 'three-generation' families. Three models have four belted travelling seats and two layouts can have six, ideal for children and grandchildren.



Upgraded soft furnishings, new locker doors in contemporary 'Aralie Sen' woodgrain and chrome push button locker catches give a much more upmarket feel.

Exclusive to Swift Group and designed to give you the ultimate nights sleep, an exclusive Duvalay Duvalite mattress, with lightweight memory fibre technology comes fitted in all fixed bed models.

For added luxury the Comfort Pack now also includes a Winter Pack and Status 550 TV aerial in addition to cab air-conditioning, passenger air bag, electric entrance step, concertina door flyscreen and pleated windscreen blind. It's so keenly priced you are sure to select it.



ESCAPE FEATURES

Chassis-Cab

- **New** Generation Fiat chassis cab with daytime running lights
- Fiat Euro 5+ 130bhp, 2.3 litre engine
- **New** Dashboard design with fully integrated factory-fit Radio/MP3 player with Bluetooth and switch-off timing adjustable up to 3 hours
- **New** Integrated radio aerial within electric wing mirrors
- Cab battery isolation switch to prevent discharge in storage
- Electrically operated and tinted cab windows
- Remote central locking of cab doors and immobiliser with rolling code
- Thermal cab Side window covers
- ABS brakes with EBD (electronic brake force distribution)
- Variable power steering
- Adjustable steering wheel position
- Driver's airbag
- Headlamp height adjustment
- **New** Captains chairs with twin armrests and integrated headrest
- **New** Central cup holder with slot for full width tablet and wall pocket for smart phone with USB port for charging
- Door pockets with bottle holders
- Two 12v sockets
- Driver and passenger seats in 622, 624, 686 & 696 models with:
 - Position and rake adjustment (driver's seat also has height adjustment)
 - Two armrests
 - Full upholstered covers
 - Base surrounds
- Driver and passenger seats in 644 & 664 model with:
 - Position, height and rake adjustment
 - Swivels
 - Two armrests
 - Full upholstered covers
 - Base surrounds
- Cab carpet (removable)
- Spare wheel on under slung carrier
- Thatcham (Category 7) approved TRACKER Retrieve fitted as standard

Body and Exterior Equipment

- **New** SMART construction with strong, moisture proof 'PURE' Polyurethane timberless framed body shell
- One-piece, 5000 Series marine grade aluminium sidewalls

- **New** Dynamic graphics coordinated with white cab
- **New** High gloss moulded skirts and lower rear panel in white
- **New** External white gloss corner cappings for sleeker appearance
- Full wheel trims
- Low energy LED exterior light
- High level brake light
- Main habitation door with 2 point locking system and integrated door retainer
- Single key for all habitation doors
- Stepwell and manually retractable step with buzzer warning
- Exterior access locker door - 622 & 664 models
- 'Garage' door - 696 model only
- Double glazed opening windows with night-latch ventilation
- Compartment for 2 x 7kg gas bottles
- Gas regulator suitable for Butane or Propane
- High and Low Fixing points for rear-mounted cycle rack
- 32mm 'sandwich' walls with HD polystyrene insulation core
- 32mm 'sandwich' roof with HD polystyrene insulation core
- 44mm 'sandwich' floor with WBP plywood and Styrofoam insulation core
- Low level ventilation moved from step well to reduce road noise
- Heavy duty chassis extensions ready for optional homologated towbar

Living Area

- 'Toulon' soft furnishing scheme with two scatter cushions
- **New** 'Aralie Sen' woodgrain with contemporary colouring
- **New** Locker style with push button chrome handles
- Lap and diagonal seat belts on all designated passenger seats
- High resilience foam in seats and backrests (150mm/6")
- Seat tops with beech slats, spring-assisted for easy access (except travelling seats)
- 75mm/3" 'Duvalay Duvalite' lutan bed mattress (High-line models) and 696 bunk mattresses
- Removable aluminium ladder to the over-cab bed (High-line models)
- French Oak effect, high impact, scratch resistant floor lino
- Exclusive 'Duvalay Duvalite' fixed bed mattress with lightweight memory fibre technology - hypoallergenic, excellent pressure relief, dustmite resistant and 100% recyclable
- Removable carpets

- Heki rooflight in lounge area with flyscreen and adjustable pleated blind
- Cassette flyscreens and blinds on all windows
- Removable entrance mat
- Smoke alarm
- Carbon monoxide alarm

Kitchen

- Dometic 80 litre manual selection fridge with 230V, gas and 12V operation
- Combination thermostatic oven and grill with electronic ignition
- Granite effect moulded kitchen sink
- Contrast 'Grey white' kitchen upper locker doors
- **New** Lighting in china locker
- Removable drainer with dedicated storage
- Food grade nylon chopping board with dedicated storage
- **New** Vector chrome effect mixer tap
- 3 burner gas hob with electronic ignition
- **New** Microwave oven
- Kitchen rooflight with flyscreen and blind

Washroom

- Ecocamel shower hose and head uses less water while giving a powerful shower
- 35mm thick entrance door with domestic style mortice lock and handle
- Thetford C260 cassette toilet with electric flush and 18 litre wheeled holding tank
- Overhead towel locker
- **New** Vector chrome effect mixer tap
- Rooflight with flyscreen (622, 644, 686 & 696)
- Opening window (except 622, 644, 686 & 696)

Heating and Plumbing

- Grade 3 classification (EN 1646-1) for heating and thermal insulation (for sub-zero ambient temperatures)
- **New** Dual fuel heating with Truma Combi 4 1.8kW electric/4kW gas/4.8kW combined (Combi 6 1.8kW electric/6kW gas/5.8kW combined in 686 & 696)
- **New** Truma 'Crash sensing Mono' regulator for en-route use of heating and water heating
- **New** Drawer storage under oven (model specific)
- **New** Kitchen work top extension flap
- Pressurised fresh water system with self-priming pump & accumulator
- 65 litre internal fresh water tank with level sensor
- 68 litre waste water tank with level sensor
- **New** Waste drain valve actuation point including brace

Electrical

- Mains consumer unit with mains isolators and 12V fuse board
- Large, easy to read 12V control panel near entrance doorway with controls for:
 - 12V power on/off
 - Battery selection and charge state
 - Water pump
 - Tank levels
- **New** Enhanced ultra low energy lighting system:
 - LED spotlights
 - LED ceiling lights
- Three chrome 230V sockets
- 300 Watt charger/transformer for 12V supply
- 80 amp-hour leisure battery in exterior access locker
- External aerial connection point in battery locker
- TV station with 230V and 12V sockets, aerial socket
- 25 metre mains hook-up cable

Key options

- Comfort-Matic automatic gearbox with Fiat Euro 5+ 130bhp 2.3 litre engine (only available in conjunction with Comfort Pack)
- Special Value Comfort Pack consisting of:
 - Cab air-conditioning
 - Passenger air bag
 - Electric entrance step with automatic drive-away retraction
 - Easy action concertina door flyscreen
 - Pleated windscreen blind
 - **New** Status 550 TV aerial
- **New** Winter Pack with:
 - Waste water tank heater
 - Under floor Waste pipe insulation
 - Fridge vent covers
- Six seat belt option on 686 & 696 models

1. **New** Dashboard design with fully integrated factory-fit Radio/MP3 player with Bluetooth, switch-off timing adjustable up to 3 hours
2. **New** Captains chairs with integrated headrest, wider backrest, better side support and improved seat comfort
3. **New** External white gloss corner cappings and side skirts or sleeker appearance
4. Cab battery isolation switch to prevent discharge in storage
5. Spare wheel on under slung carrier
6. **New** Microwave oven
7. Combination thermostatic oven and grill with electronic ignition
8. Dometic 8-Series 85 litre manual fridge with 230V, gas and 12V operation
9. Seitz high specification entrance door with secure 2-point locking and door retainer
10. **New** Dual fuel heating with Truma Combi 4 1.8kW electric/4kW gas/4.8kW combined and Truma 'Crash sensing Mono' regulator for en-route use (Combi 6 in 686 and 696)
11. Heki rooflight in lounge area with flyscreen and adjustable pleated blind
12. **New** Locker style with positive catches on all overhead locker doors for secure storage on the move and **New** 'Aralie Sen' Woodgrain with contemporary colouring
13. **New** Enhanced ultra low energy lighting system with LED spot and ceiling light
14. Seat bases with beech slats, spring assisted for easy access (Except traveling seats)
15. Exclusive 'Duvalay Duvalite' fixed bed mattress with lightweight memory fibre technology - hypoallergenic, excellent pressure relief, dustmite resistant and 100% recyclable
16. **New** Status 550 TV aerial (Part of Comfort Pack)

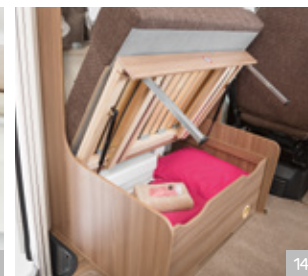
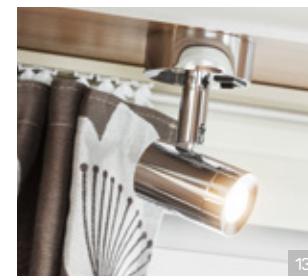
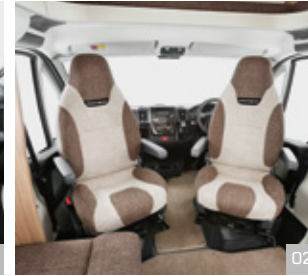

JOIN US ONLINE

Social Network for Motorhome Enthusiasts



FIND US ON SOCIAL NETWORKS

ESCAPE SPECIFICATION



	622		624		644	
	Standard	Optional	Standard	Optional	Standard	Optional
Fiat MultiJet Diesel Engine	130	130 Auto	130	130 Auto	130	130 Auto
Engine Capacity	2287cc		2287cc		2287cc	
Engine Power	96kW @ 3600rpm		96kW @ 3600rpm		96kW @ 3600rpm	
Engine Torque	320Nm @ 1800rpm		320Nm @ 1800rpm		320Nm @ 1800rpm	
Roof Profile	Low-line		High-line		High-line	
Wheel Base	3.45m / 11' 4"		3.45m / 11' 4"		3.45m / 11' 4"	
Seat Belts (inc. driver)	2		4		4	
Berths (Sleeping Positions)	2		5		4	
Overall Length (No Ladder)**	6.30m / 20'8"		6.30m / 20'8"		6.30m / 20'8"	
Overall Body Width (Mirrors folded)	2.31m / 7'7"		2.31m / 7'7"		2.31m / 7'7"	
Overall Height*	2.85m / 9'4"		2.94m / 9'8"		2.94m / 9'8"	
Optional Awning	Thule 4900 3.5m		Thule 4900 3.5m		Thule 4900 3.5m	
Maximum Technical Permissible Laden Mass (A)	3300kg		3300kg		3300kg	
Mass in Running Order (B)	2777kg	2794kg	2880kg*	2897kg*	2886kg*	2903kg*
Maximum User Payload (A-B)	523kg	506kg	420kg*	403kg*	414kg*	397kg*
Essential Habitation Equipment	10kg		10kg		10kg	
Thermal Insulation Grade	THREE		THREE		THREE	
Recommended Maximum Trailer Weight	1600kg		1600kg		1600kg	
Gross Train Weight	4900kg*		4900kg*		4900kg*	
BED SIZES						
Front Double			1.87m x 1.22m / 6'2" x 4'0"			
Front Nearside Single			1.85m x 0.68m / 6'1" x 2'3"			
Front Offside Single			1.87m x 0.92m / 6'2" x 3'0"			
Rear Double	2.08m x 1.34m / 6'10" x 4'5"				2.08m x 1.34m / 6'10" x 4'5"	
Rear Bunk Upper						
Rear Bunk Lower						
Overcab Bed			2.08m x 1.37m / 6'10" x 4'6"		2.08m x 1.37m / 6'10" x 4'6"	

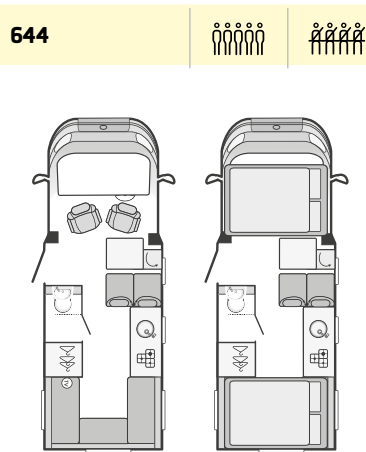
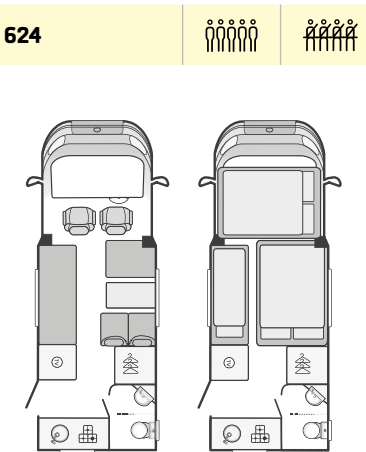
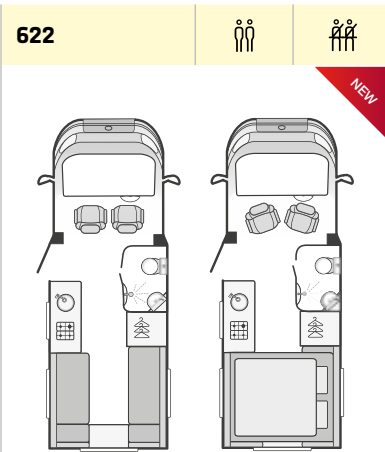

	664		686		696	
	Standard	Optional	Standard	Optional	Standard	Optional
Fiat MultiJet Diesel Engine	130	130 Auto	130	130 Auto	130	130 Auto
Engine Capacity	2287cc		2287cc		2287cc	
Engine Power	96kW @ 3600rpm		96kW @ 3600rpm		96kW @ 3600rpm	
Engine Torque	320Nm @ 1800rpm		320Nm @ 1800rpm		320Nm @ 1800rpm	
Roof Profile	Low-line		High-line		High-line	
Wheel Base	3.80m / 12'6"		4.04m / 13'3"		4.04m / 13'3"	
Seat Belts (inc. driver)	4		5 (Opt 6)		5 (Opt 6)	
Berths (Sleeping Positions)	4		6		6	
Overall Length (No Ladder)**	6.72m / 22'1"		6.92m / 22'8"		6.92m / 22'8"	
Overall Body Width (Mirrors folded)	2.31m / 7'7"		2.31m / 7'7"		2.31m / 7'7"	
Overall Height*	2.85m / 9'4"		2.94m / 9'8"		2.94m / 9'8"	
Optional Awning	Thule 4900 4.0m		Thule 4900 4.0m		Thule 4900 4.0m	
Maximum Technical Permissible Laden Mass (A)	3500kg		3500kg †		3500kg †	
Mass in Running Order (B)	2894kg*	2911kg*	3010kg*	3027kg*	3015kg	3032kg
Maximum User Payload (A-B)	606kg*	589kg*	490kg*	473kg*	485kg	468kg
Essential Habitation Equipment	10kg		10kg		10kg	
Thermal Insulation Grade	THREE		THREE		THREE	
Recommended Maximum Trailer Weight	1600kg		1600kg		1600kg	
Gross Train Weight	5100kg		5100kg*		5100kg*	
BED SIZES						
Front Double	2.08m x 1.24m / 0.93m / 6'10" x 4'1" / 3'1"		1.82m x 1.22m / 6'0" x 4'0"		2.08m x 1.36m / 6'10" x 4'6"	
Front Nearside Single						
Front Offside Single						
Rear Double	1.85m x 1.25m / 6'1" x 4'1"		1.82m x 0.92m / 6'0" x 3'0"		1.84m x 0.92m / 6'0" x 3'0"	
Rear Bunk Upper						
Rear Bunk Lower						
Overcab Bed			2.08m x 1.37m / 6'10" x 4'7"		2.08m x 1.37m / 6'10" x 4'6"	

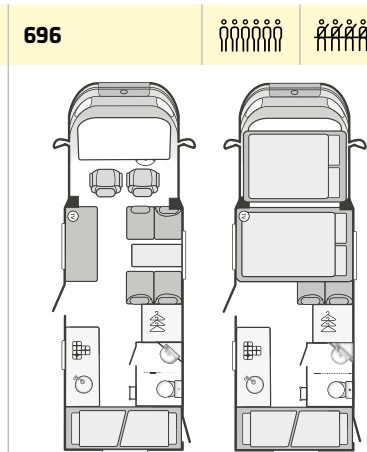
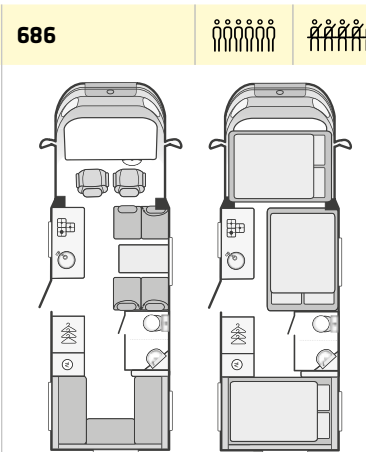
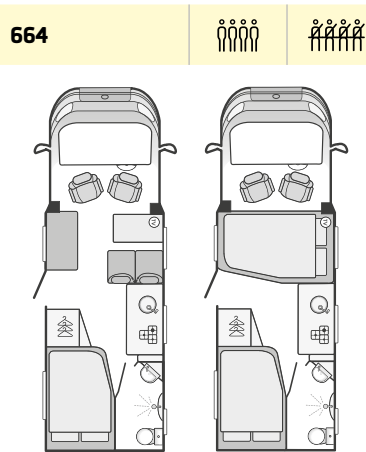

- Note**
- The Maximum User Payload includes:
 - the conventional load (this is the allowance for passengers)
 - essential habitation equipment (items and fluids required for safe and proper functioning of habitation equipment)
 - optional equipment (items available from the manufacturer over and above the standard specification)
 - personal effects (those items not covered by the above)
 - The Mass in Running Order is the mass of the unladen vehicle including a 75kg allowance for the driver plus engine coolants and 90% of the fuel tank and 100% gas capacity.
The MRO is calculated with the fresh water tank empty. If you travel with water in the fresh water tank then the payload will reduce accordingly.
 - Please take care to ensure that you have allowed for the masses of all items you intend to carry in the motor caravan, e.g. passengers, optional equipment, essential habitation equipment and personal effects, such as clothing, food, pets, bicycles, sailboards, sports equipment etc.
 - Warning - under no circumstances should the maximum technical permissible laden mass of this motor caravan be exceeded.
- * Estimated
** For optional roof ladder add 125mm to length 40mm to height on low-line.
- # With this vehicle configuration it will be necessary to reduce the payload carried inside the van when towing to ensure that the MTPLM and maximum axle loads are not exceeded.

† Optional 6th Belted Seat on 686 & 696

An extra seat belt can be added to the dinette allowing 6 people to travel:

Belted seats	6
MTPLM	3650kg
Gross Train Weight	5250kg

All other specification as table

EXCLUSIVE TO
SWIFT GROUP



Exclusive to the Swift Group is the fitting of a 'Duvalay Duvalite' mattress in fixed bed layouts. Brought to recognition on Dragon's Den and now backed by Hilary Devey, the 'Duvalay Duvalite' is a new innovative mattress made with lightweight memory fibre technology. This hypoallergenic fibre remains as comfortable as memory foam but has many other benefits. Helping eliminate heat retention it gives superior temperature harmony, excellent pressure relief and is durable and resilient. It is resistant to dust-mites and is 100% recyclable. Being ultra light weight it also contributes to significant weight savings.

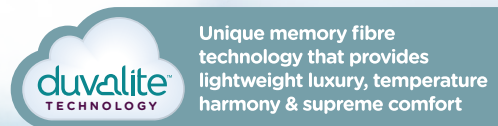

TRACKER Retrieve has been chosen exclusively by Swift Group since 2013 to be fitted to all its motorhomes as one of the most effective tracking systems available. With 20 years' experience it is the only vehicle tracking company supported by all UK police forces, therefore providing unrivalled protection. Powered by its own battery it is ideal while the vehicle is in use or in storage.

All TRACKER's stolen vehicle recovery (SVR) solutions use Very High Frequency (VHF) technology which offers the ultimate level of security, enabling police to locate stolen motorhomes even when they are concealed in containers, lock-ups, underground car parks or shipped abroad. Its technology is used by all police forces in the UK, confirming the power of TRACKER's SVR solutions.



Glamour Shield is the UK's official provider of Supagard™ paint and fabric protection solutions to the leisure vehicle industry and the only provider recommended by Swift Group.

Supagard™ professional paint sealant has been professionally applied to vehicles for over 20 years and is guaranteed to protect your motorhome's exterior from acid rain, UV rays, atmospheric pollutants, road salt and other causes of exterior fading and degradation.

Supagard™ InteriorGuard prevents spills of coffee, soft drinks, juices and other liquids from permanently staining your fabrics and carpets, protecting your interior against those occasional mishaps.

Supagard™ is only available as an optional extra. Ask your dealer for details.

BUILD MARQUES

All Swift Group coachbuilt motorhomes come with a market leading 10 year bodyshell integrity warranty which is backed by Swift Group to give you extra peace of mind.

They are also NCC and European Whole Vehicle Type approved, which means they have been built to comply with strict weight, dimension and safety regulations.

Finally, all Swift Group Motorhomes meet BS EN 1646-1 the motorhomes standard for Grade 3 heating and thermal insulation, which means the interior warms up from minus 15°C to 20°C in under 4 hours and the water system still works. Swift Group proves this by using cold chamber testing.



SWIFT TV



[WWW.SWIFTTV.CO.UK](http://www.swifttv.co.uk)

See product videos · developments and interviews at swifttv.co.uk

